

THE PROPERTY OF THE DRAWING IS ESTABLISHED BY LAW. IT IS FORBIDDEN TO PRODUCE OR SHOW IT TO THIRD PARTY, WITHOUT A WRITTEN AGREEMENT.

Item	Name	Q.ty
1	05.01.005.01.10	1
2	05.01.005.02	1
3	05.01.005.05	1
4	05.01.005.06	2
5	M.8x35.6N	1
6	R.10.SCH	2

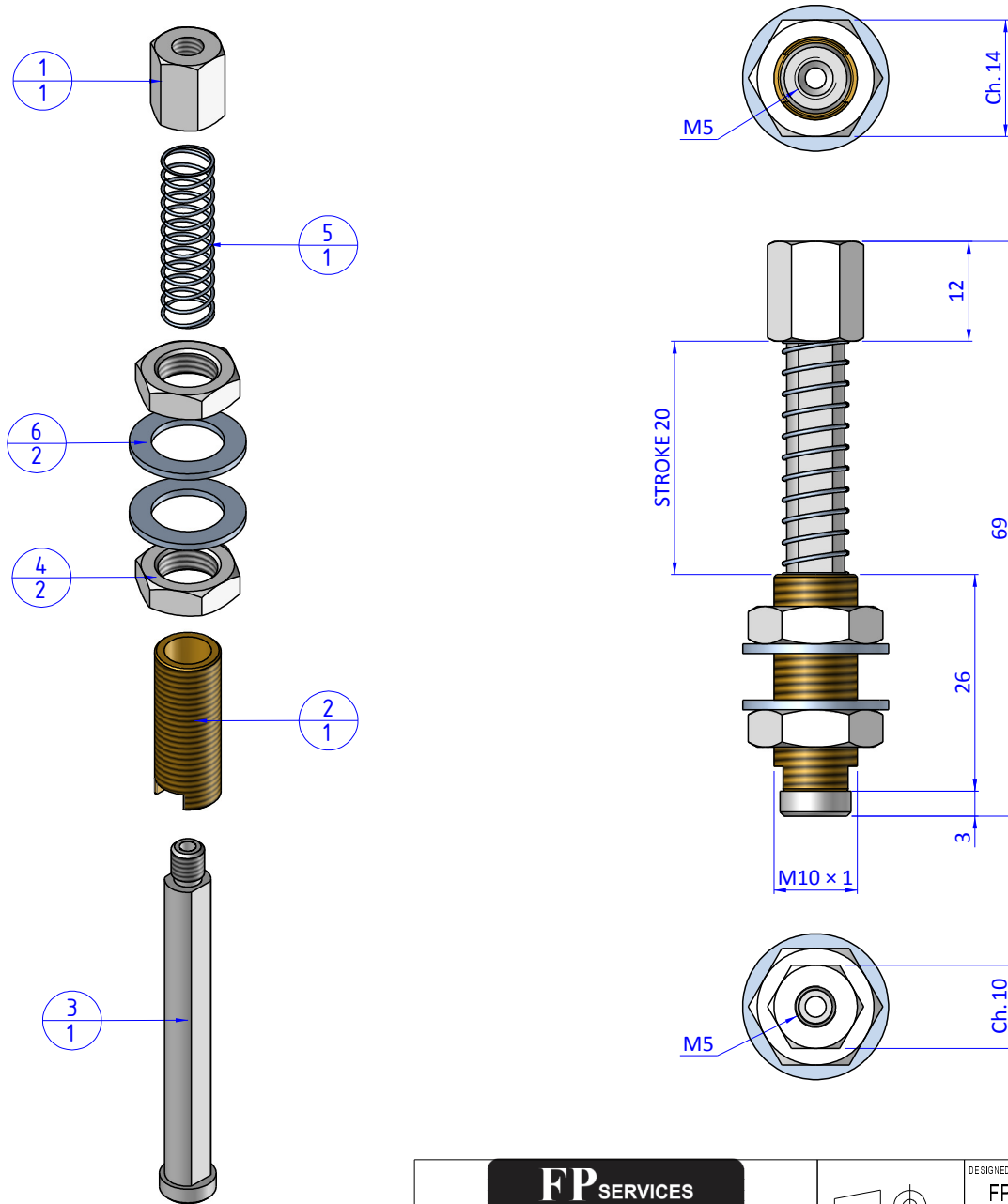

Format A3

UNI 936-76

		DESIGNED FROM		REVIEW
		FPSERVICES		A
GENERAL TOLERANCE		DATE	WEIGHT	
UNI - ISO 2768		12/02/2019	0,031kg	
CLASSE f		CODE		
		CA.05.01.005.6N		CA.05.01.005.6N